

Centrifugal Roof Exhaust Fan

Belt Drive - Direct Drive

Type : **DV-DVW**

Vertical outlet



Saudi Fan[®]
I n d u s t r i e s

2nd Industrial City
T e l . 8 1 2 1 8 6 6
F a x . 8 1 2 1 8 9 4
Email: rhadmin@refhouse.com
www.refhouse.com



Saudi Fan Industries

Management Commitment To Quality

We are continuously striving to provide higher quality products and services to achieve total customer satisfaction by understanding their requirements and anticipating their future expectations or needs.

We are committed to development and strengthening of partnership with our external and internal customers and suppliers.

We are dedicated to the continual improvement of all products and services through involvement of all employees.

We value all people by understanding and drawing upon their strengths i.e. abilities and knowledge and make efforts for their training and development.

President

Ali Saleh Al-Khalaf

Table of Contents

• Management Commitment to Quality	1
• Company Profile	2
• General Technical Information	3
• Fan Introduction	4
• Standard Construction Features	5
• Fan Performance curves and Technical data	6
• Options & Accessories	17
• Typical Application	19
• Prestart Check list	20
• Warranty	21
• Contacts / Inquiries	22

Company Profile

Saudi Fan Industries was established In 1999 as another manufacturing division of steadily growing organization “**Refrigeration House group**” in order to fulfill requirements of local market for air movement and control equipment’s.

As a member of Refrigeration House Group , that has market research for ventilation equipment’s spread over 25 years ,Saudi Fan industries now has grown into a full swing manufacturing unit to satisfy the demanding needs of air movement and control equipment’s for modern residential ,commercial and industrial zones .

Since its establishment, Saudi Fan Industries has acquired modern manufacturing technology in order to achieve “**Total Customer Satisfaction**”. Not only still it has been investing significant resources in latest technology but also has created a medium where everyone in the organization can contribute. We have a stringent policy of research, development and making awareness of technology throughout the organization .**Saudi Fan Industries has been implemented Quality Assurance Management System as per EN ISO 9001:2008 Standard.** As a result, Saudi Fan Industries products are manufactured precisely and consistently through all production stages under strict quality control procedures.

Saudi Fan Industries strictly acting on the policy of “**The high quality product should be delivered to our valued customer’s right from the beginning**”.

Now Saudi Fan Industries is not only the leading supplier of air movement and control equipment in Kingdom but also a famous name in entire gulf. It offers wide range of fans and ventilator products for residential, commercial, institutional and industrial buildings in applications from comfort ventilation to manufacturing processes.

Products are available for exhaust, supply, re-circulate, filtered, process and gravity applications. Fans are available in either direct drive or belt drive.

Saudi Fan Industries has significant production capacity in order to fulfill markets demand. It also has a pool of qualified staff, who are fully dedicated to give best advice to our valued customer’s inquires.



Performance certified by AMCA Accredited Laboratory for installation Type A : free inlet, free outlet per AMCA Standard 210. Performance rating includes the effects of a bird screen and windband

General Technical Information

Fan Laws

Speed Variation at constant fan size and constant density :

The volume flow changes proportionately to the speed .

$$\frac{V_1}{V_2} = \frac{n_1}{n_2}$$

All pressures (static, dynamic and total) change proportionately to the square of speed .

$$\frac{P_{st1}}{P_{st2}} = \left(\frac{n_1}{n_2}\right)^2 = \left(\frac{V_1}{V_2}\right)^2$$

The Power requirement changes proportionately to the third power of speed

$$\frac{P_1}{P_2} = \left(\frac{n_1}{n_2}\right)^3 = \left(\frac{V_1}{V_2}\right)^3$$

In the case of changes in the wheel diameter of geometrically similar wheels at constant speed :

The volume flow change proportionately to the third power of the wheel diameter .

$$\frac{V_1}{V_2} = \left(\frac{D_1}{D_2}\right)^3$$

All pressures (static, dynamic and total) change proportionately to the square wheel diameter .

$$\frac{P_{st1}}{P_{st2}} = \left(\frac{D_1}{D_2}\right)^2$$

The Power requirement change proportionately to the fifth power of wheel diameter .

$$\frac{P_1}{P_2} = \left(\frac{D_1}{D_2}\right)^5$$

Changes in the density at constant speed or change of Kelvin temperature at a constant flow medium :

The volume flow is not affected.

$$V = \text{Constant}$$

All pressures (static, dynamic and total) changes proportionately to the density .

$$\frac{P_{st1}}{P_{st2}} = \frac{\rho_1}{\rho_2} = \frac{T_2}{T_1}$$

The Power requirement changes proportionately to the density

$$\frac{P_1}{P_2} = \frac{\rho_1}{\rho_2} = \frac{T_2}{T_1}$$

Pressure Units

Convert from	Convert to										
	Pa (N/m ²)	bar	atmosphere	mm Hg	mm H ₂ O	m H ₂ O	kg/cm ²	lb/ ft ²	lb/ in ² (psi)	inches Hg	inches H ₂ O
Pa (N/m ²)	1	10 ⁻⁵	9.87 10 ⁻⁶	0.0075	0.1	10 ⁻⁴	1.02 10 ⁻⁵	0.021	1.45 10 ⁻⁴	2.96 10 ⁻⁴	4.02 10 ⁻³
bar	105	1	0.987	750	1.019 10 ⁴	10.197	1.0197	2090	14.5	29.61	402
atmosphere	1.01 10 ⁵	1.013	1	759.9	10332	10.332	1.03	2117.5	14.69	29.92	407
mm Hg = 1Torr	133.3	1.33 10 ⁻³	1.32 10 ⁻³	1	13.3	0.013	1.36 10 ⁻³	2.79	0.019	0.039	0.54
mm H ₂ O	10	0.000097	9.87 10 ⁻⁵	0.075	1	0.001	1.02 10 ⁻⁴	0.209	1.45 10 ⁻³	2.96 10 ⁻³	0.04
m H ₂ O	104	0.097	9.87 10 ⁻²	75	1000	1	0.102	209	1.45	2.96	40.2
kg/cm ²	9.8 10 ⁴	0.98	0.97	735	10000	10	1	2049	14.21	29.03	394
lb/ ft ²	47.8	4.78 10 ⁻⁴	4.72 10 ⁻⁴	0.36	4.78	4.78 10 ⁻³	4.88 10 ⁻⁴	1	0.0069	0.014	0.19
lb/ in ² (psi)	6894.76	0.069	0.068	51.7	689.7	0.69	0.07	144	1	2.04	27.7
inches Hg	3377	0.0338	0.033	25.4	337.7	0.337	0.034	70.8	0.49	1	13.57
inches H ₂ O	248.8	2.49 10 ⁻³	2.46 10 ⁻³	1.87	25.4	0.0254	0.0025	5.2	0.036	0.074	1

Volume Flow Units

Convert from	Convert to										
	m ³ /s	m ³ /min	m ³ /h	liter/sec	liter/min	liter/h	cfm	US gpd	US gpm	IMP gpd	IMP gpm
m ³ /s	1	60	3600	1000	60000	3600000	2119	22800000	15852	19000000	13200
m ³ /min	0.0167	1	60	16.67	1000	60000	35.32	380000	264.2	316667	220
m ³ /h	0.000278	0.0167	1	0.278	16.67	1000	0.589	6333.3	4.403	5277.8	3.67
liter/sec	0.001	0.06	3.6	1	60	3600	2.119	22800	15.852	19000	13.2
liter/min	1.67 10 ⁻⁵	0.001	0.06	0.0167	1	60	0.0353	380	0.2642	316.7	0.22
liter/h	2.7 10 ⁻⁷	0.000017	0.001	0.00028	0.0167	1	0.00059	6.33	0.0044	5.28	0.0037
cfm	0.00047	0.028	1.699	0.472	28.32	1698.99	1	10760.3	7.48	8966.9	6.23
US gpd	4.39 10 ⁻⁸	2.6 10 ⁻⁶	0.000158	0.000044	0.0026	0.158	0.000093	1	0.000695	0.833	0.000579
US gpm	0.000063	0.00379	0.227	0.063	3.785	227.1	0.1337	1438.3	1	1198.6	0.833
IMP gpd UK	5.26 10 ⁻⁸	3.2 10 ⁻⁶	0.000189	5.26 10 ⁻⁵	0.00316	0.1895	0.00011	1.2	0.00083	1	0.00069
IMPgpm UK	0.000076	0.0046	0.272	0.076	4.55	272.7	0.161	1727.3	1.2	1439.4	1

Fan Introduction

- Saudi fan industries provides Industry's best performance centrifugal roof fans for general clean air and kitchen applications.
- Performance Capabilities range up to 20000 CFM and 3.00 In. Wg (747 Pa) of Static Pressure
- Each fan shall bear a metal name plate containing model number.

Advantages

- Built in motor protection through thermal overload as standard.
- Performance as cataloged is assured. All fan sizes are tested in our AMCA Accredited Laboratory,
- A range of useful accessories available for different application.

Application

- Roof units are used for
 - 1.Clean air application.
 - 2.Kitchen and Restaurant application (Completed with grease trap and cooling tube.)
 - 3.Hazardous area application.

<u>Reference Code</u>		D	V	W	310	0.25	D	EX
							B	K*
D	Roof fan	—	—	—	—	—	—	—
V	Vertical	—	—	—	—	—	—	—
W	Impeller with improved efficiency	—	—	—	—	—	—	—
	Impeller diameter	—	—	—	—	—	—	—
	Motor Kw	—	—	—	—	—	—	—
B / D	Belt / Direct	—	—	—	—	—	—	—
K	Kitchen	—	—	—	—	—	—	—
*	Fan completed with Grease trap and cooling tube.							
EX								
	DEX Direct drive explosion proof							
	BEX Belt drive explosion proof							

Standard Construction Features

- Base, Motor Plate

Fan Base made from heavy gauge aluminum for model 310 up to 630 and from model 800 up to 1000 is galvanized steel sheet.

Motor plate is made from Galvanized steel sheet

- Impellers

Backward curved impellers made from sea water resistant aluminum, mounted onto the drive shaft .The impellers with shaft are statically and dynamically balanced according to quality level G 2,5 DIN/ISO 1940.

- Vibration Isolation

Vibration isolators consist of two independent studs separated by a rubber center. Reduces vibration and noise transfer between drive system and fan housing.

- Motors

TEFC -Total Enclosed fan cooled motors with protection against humidity IP 55, Class- F, 50° C Ambient. Available at Single and Three phase Supply.

XPFC - Explosion Proof –The Explosion proof motor shall be suitable for hazardous duty and shall bear UL listed label suitable for Group 1, class C & D

- Shafts

Precisely sized, ground and polished so the first critical speed is at least 25% over the maximum operating speed. Where the shaft makes contact with bearings, close tolerances result in longer bearing life.

- Bearings

Cast iron frame pre-lubricated self-aligning ball bearing. The low noise precision ball bearings are designed for a theoretical life of at least 200,000 working hours.

- Drive Assembly

Belts, pulleys and keys are oversized 150% of driven horsepower. Belts are static-free and oil-resistant

- Motor Cover

Constructed of aluminum. Attached with stainless steel fasteners for easy removal and access to the motor compartment and drive assembly.

- Windband

One-piece, heavy-gauge aluminum with a rolled bead for extra strength directs exhaust air away from the mounting surface.

- Internal Supports

Heavy-gauge supports provide additional strength to withstand winds and supports motor and drives.

- Curb Cap with Mounting Holes

One-piece for a weather-tight fit. Constructed of aluminum with an integral deep spun venturi. Aluminum curb cap has pre-punched mounting holes to ensure correct attachment to the roof.

- Drain

Allows for one-point drainage of water, grease and other residues.

- Galvanized Birdscreen

Rigid wire protects the fan discharge from birds and small objects. Standard on all sidewall fan models.

Anti –Spark Construction:

Fan is fitted with an Aluminium Wheel and an Aluminium Curb cap to realize minimum level of protection “SPARK RESISTANT” Construction as per AMCA “C” requirements.

Fan is Centrifugal exhaust type, with aluminium backward inclined centrifugal wheel .The fan inlet venturi has round curved section to smoothly transit the air to the wheel cone. The wheel is statically and dynamically balanced to Level G2.5 as per ISO standard No.1940.

The fan housing Wheel and curb cap are constructed of heavy gauge aluminium alloy.

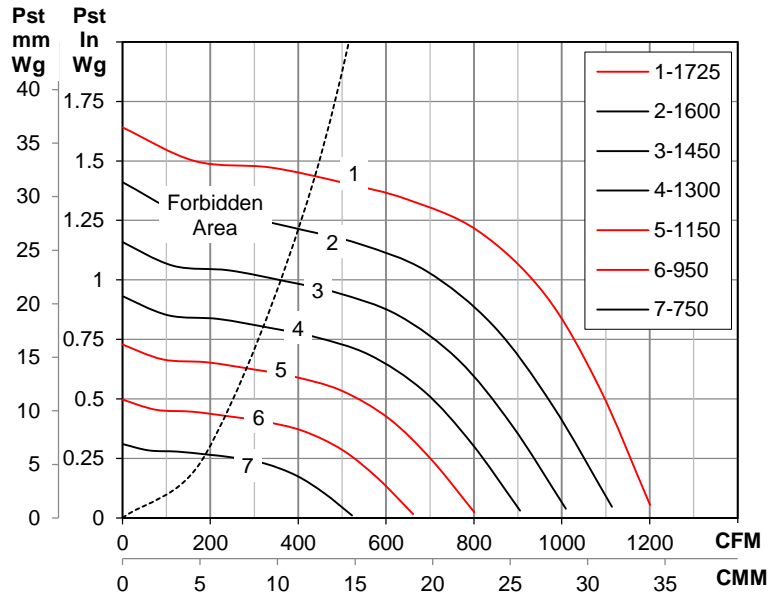
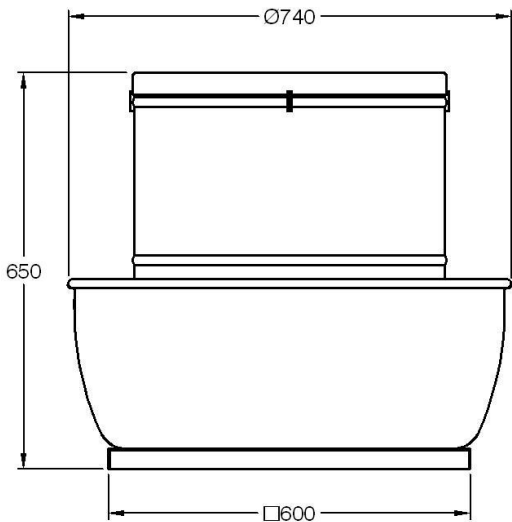

Damper Size = 286x286
 Roof Opening = 450x450
 *Approximate Unit Weight (kg) = 33 + W_m
 (All dimensions in millimeters)
 * W_m Motor Weight (see table)

Direct Drive RPM: 1-1725 RPM, 5-1150 RPM, 6-950 RPM

Motor kW	Fan RPM		Static Pressure in Inches wg						
			0	0.125	0.25	0.5	0.75	1	1.25
310									
0.18	750	CFM	522	441					
		BKW	0.02	0.02					
	950	CFM	661	603	524				
		BKW	0.04	0.05	0.05				
	1028	CFM	715	663	594				
		BKW	0.06	0.06	0.06				
	1131	CFM	787	742	684	506			
		BKW	0.07	0.08	0.08	0.09			
	1150	CFM	800	756	700	530			
		BKW	0.08	0.08	0.09	0.09			
	1245	CFM	866	827	776	647			
		BKW	0.10	0.10	0.11	0.11			
1358	CFM	945	911	864	755	583			
	BKW	0.13	0.13	0.14	0.14	0.15			
0.25	1450	CFM	1009	979	935	837	701		
		BKW	0.16	0.16	0.17	0.17	0.18		
	1515	CFM	1054	1027	985	894	781	556	
		BKW	0.18	0.18	0.19	0.20	0.20	0.20	
0.37	1600	CFM	1114	1089	1049	968	867	716	
		BKW	0.21	0.21	0.22	0.23	0.24	0.24	
	1725	CFM	1201	1180	1143	1069	980	872	691
		BKW	0.26	0.27	0.27	0.28	0.29	0.30	0.30

Performance certified by AMCA Accredited Laboratory for installation Type A : free inlet, free outlet per AMCA Standard 210. Performance rating includes the effects of a bird screen and wind band , However the product is not bearing AMCA Certified Seal .

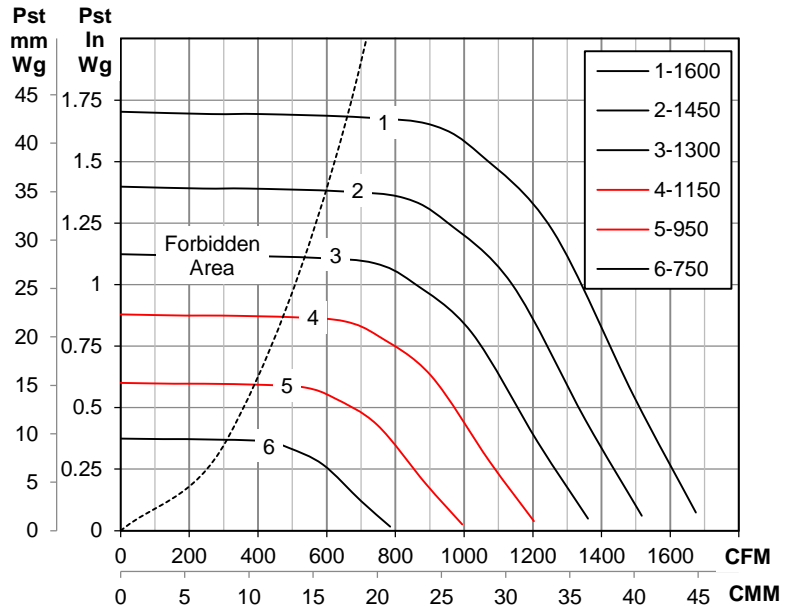
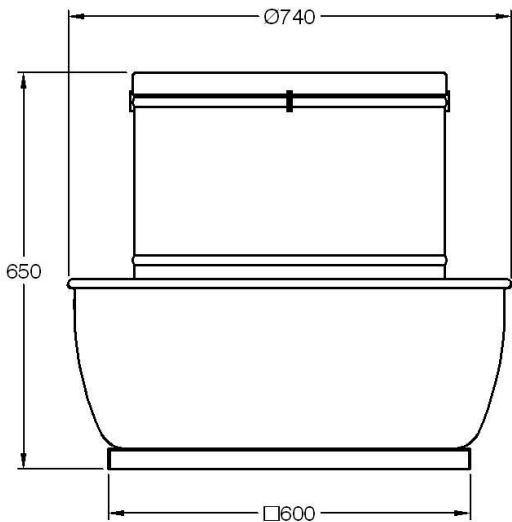

Damper Size = 438x438
 Roof Opening = 450x450
 *Approximate Unit Weight (kg) = 37+W_m
 (All dimensions in millimeters)
 * W_m Motor Weight (see table)

Direct Drive RPM : 4-1150 RPM . 5-950 RPM

Motor kW	Fan RPM		Static Pressure in Inches wg								
			0	0.125	0.25	0.5	0.75	1	1.25	1.5	
355											
0.25	750	CFM	785	697	603						
		BKW	0.03	0.03	0.03						
	825	CFM	863	785	699						
		BKW	0.04	0.04	0.04						
	950	CFM	994	930	853	666					
		BKW	0.05	0.06	0.06	0.07					
	1028	CFM	1076	1020	946	810					
		BKW	0.07	0.07	0.08	0.09					
	1150	CFM	1204	1157	1091	967	790				
		BKW	0.09	0.10	0.11	0.12	0.13				
	1220	CFM	1277	1236	1173	1055	922				
		BKW	0.11	0.12	0.13	0.14	0.15				
1265	CFM	1324	1286	1225	1111	1000	762				
	BKW	0.13	0.13	0.14	0.15	0.17	0.16				
1300	CFM	1361	1325	1266	1154	1045	858				
	BKW	0.14	0.14	0.15	0.17	0.18	0.18				
1361	CFM	1424	1392	1336	1228	1124	975				
	BKW	0.16	0.16	0.17	0.19	0.20	0.21				
0.37	1450	CFM	1518	1490	1438	1334	1237	1140	953		
		BKW	0.19	0.20	0.21	0.22	0.24	0.25	0.25		
	1551	CFM	1623	1601	1552	1453	1362	1272	1146	938	
		BKW	0.23	0.24	0.25	0.27	0.29	0.30	0.31	0.30	
0.55	1600	CFM	1675	1655	1607	1512	1422	1335	1237	1066	
		BKW	0.26	0.26	0.27	0.29	0.31	0.32	0.34	0.34	

Performance certified by AMCA Accredited Laboratory for installation Type A : free inlet, free outlet per AMCA Standard 210. Performance rating includes the effects of a bird screen and wind band , However the product is not bearing AMCA Certified Seal .

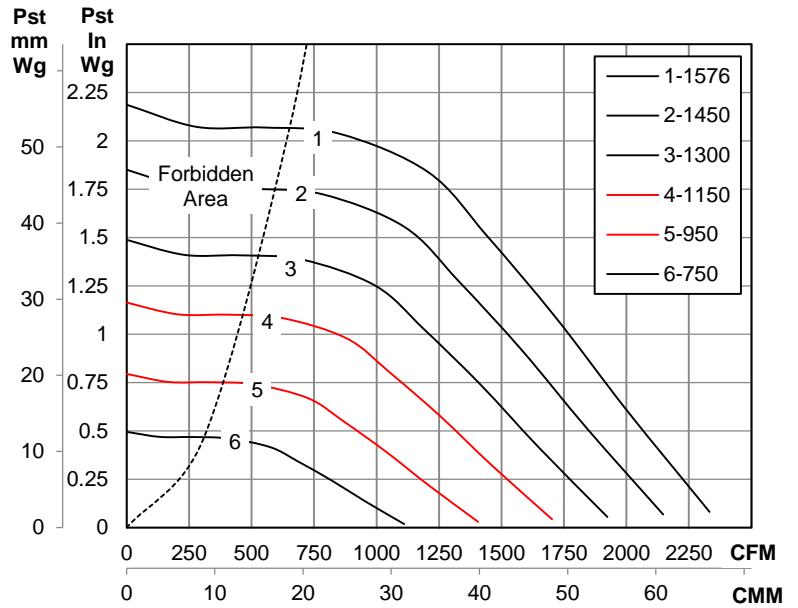
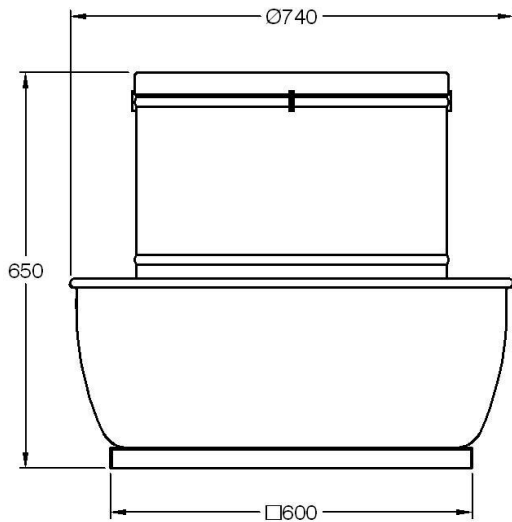

Damper Size = 438x438
 Roof Opening =450x450
 *Approximate Unit Weight (kg)= 43 +W_m
 (All dimensions in millimeters)
 * W_m Motor Weight (see table)

Direct Drive RPM : 4-1150 RPM . 5-950 RPM

Motor kW	Fan RPM		Static Pressure in Inches wg										
			0	0.125	0.25	0.5	0.75	1	1.25	1.5	2		
400													
0.37	750	CFM	1110	969	812								
		BKW	0.05	0.06	0.07								
	950	CFM	1406	1306	1177	921	358						
		BKW	0.11	0.11	0.12	0.14	0.11						
	979	CFM	1449	1354	1228	982	632						
		BKW	0.12	0.12	0.13	0.15	0.14						
	1000	CFM	1480	1388	1264	1025	737						
		BKW	0.12	0.13	0.14	0.16	0.15						
	1093	CFM	1618	1539	1426	1210	975	182					
		BKW	0.16	0.17	0.18	0.20	0.21	0.14					
	1150	CFM	1702	1631	1523	1317	1100	828					
		BKW	0.19	0.20	0.21	0.23	0.24	0.23					
	1245	CFM	1843	1783	1684	1490	1297	1086	720				
		BKW	0.24	0.25	0.26	0.28	0.30	0.31	0.27				
0.55	1333	CFM	1973	1923	1830	1646	1471	1281	1076	185			
		BKW	0.30	0.30	0.31	0.34	0.36	0.38	0.37	0.24			
	1421	CFM	2104	2062	1974	1800	1636	1464	1281	1076			
		BKW	0.36	0.36	0.38	0.40	0.43	0.45	0.46	0.44			
0.75	1498	CFM	2217	2183	2100	1934	1776	1619	1448	1268			
		BKW	0.42	0.42	0.44	0.46	0.49	0.52	0.53	0.53			
	1576	CFM	2333	2305	2226	2068	1916	1768	1610	1447	917		
		BKW	0.49	0.49	0.51	0.53	0.56	0.60	0.61	0.63	0.55		

Performance certified by AMCA Accredited Laboratory for installation Type A : free inlet, free outlet per AMCA Standard 210. Performance rating includes the effects of a bird screen and wind band , However the product is not bearing AMCA Certified Seal .

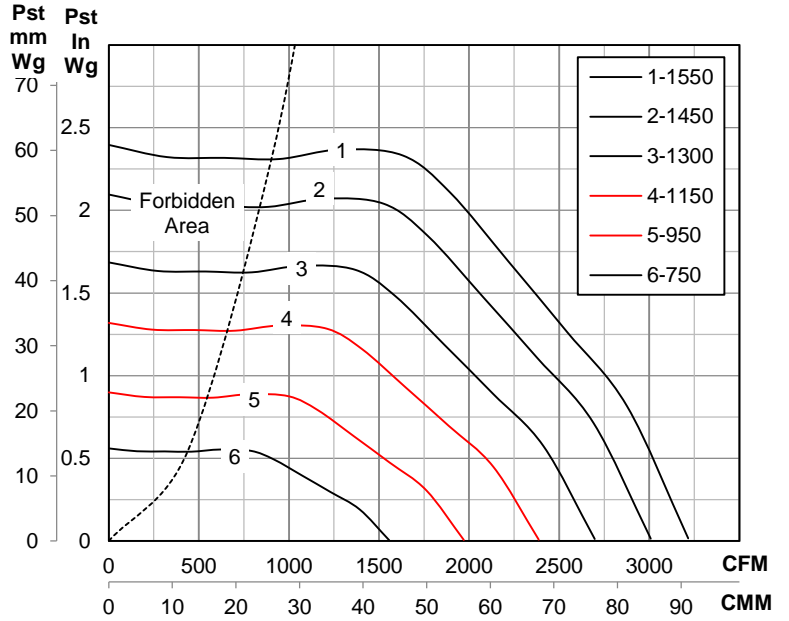
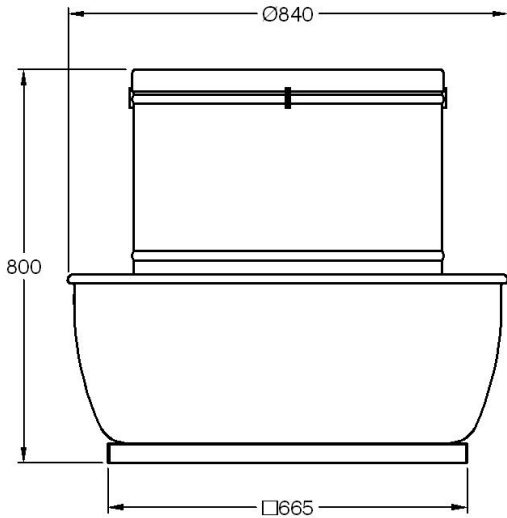

Damper Size = 438x438
 Roof Opening = 550x550
 *Approximate Unit Weight (kg) = 57 + W_m
 (All dimensions in millimeters)
 * W_m Motor Weight (see table)

Direct Drive RPM : 4-1150 RPM . 5-950 RPM

Motor kW	Fan RPM		Static Pressure in Inches wg									
			0	0.125	0.25	0.5	0.75	1	1.25	1.5	2	
450												
0.55	750	CFM	1556	1450	1301	901						
		BKW	0.10	0.11	0.12	0.13						
	884	CFM	1834	1745	1652	1332	948					
		BKW	0.17	0.17	0.18	0.21	0.20					
	950	CFM	1971	1889	1802	1528	1214					
		BKW	0.21	0.22	0.22	0.25	0.26					
	1007	CFM	2090	2012	1931	1691	1397	74				
		BKW	0.25	0.26	0.26	0.29	0.31	0.19				
	1078	CFM	2237	2165	2089	1888	1617	1339				
		BKW	0.31	0.31	0.32	0.35	0.37	0.38				
1150	CFM	2386	2320	2248	2083	1832	1573	1264				
	BKW	0.37	0.38	0.39	0.41	0.44	0.46	0.44				
0.75	1212	CFM	2515	2452	2385	2248	2011	1767	1520			
		BKW	0.44	0.44	0.45	0.47	0.51	0.54	0.53			
	1275	CFM	2646	2587	2522	2393	2188	1958	1724	1453		
		BKW	0.51	0.52	0.52	0.54	0.58	0.61	0.62	0.61		
1.10	1300	CFM	2698	2640	2577	2450	2257	2033	1804	1565		
		BKW	0.54	0.55	0.56	0.57	0.61	0.65	0.66	0.65		
	1450	CFM	3005	2954	2897	2784	2657	2458	2256	2052	1568	
		BKW	0.74	0.75	0.76	0.78	0.81	0.86	0.89	0.92	0.88	
1.50	1550	CFM	3216	3170	3117	3011	2905	2740	2554	2364	1978	
		BKW	0.91	0.92	0.93	0.95	0.97	1.02	1.07	1.10	1.12	

Performance certified by AMCA Accredited Laboratory for installation Type A : free inlet, free outlet per AMCA Standard 210. Performance rating includes the effects of a bird screen and wind band , However the product is not bearing AMCA Certified Seal .

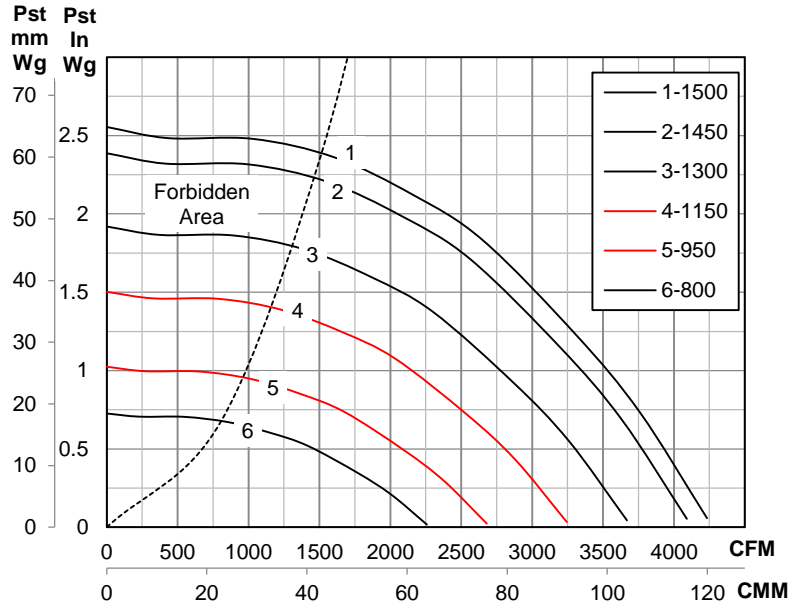
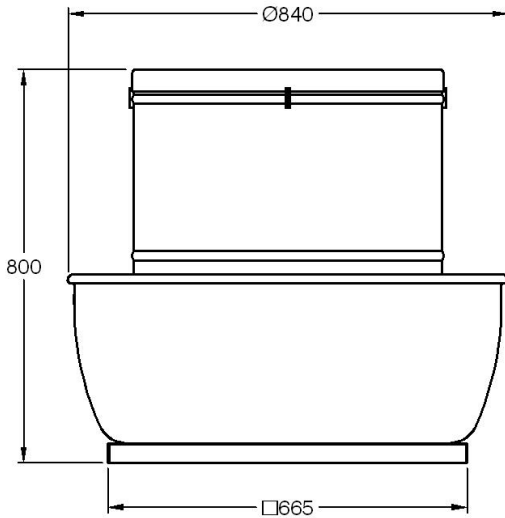

Damper Size = 438x438
 Roof Opening = 550x550
 *Approximate Unit Weight (kg) = 59 +W_m
 (All dimensions in millimeters)
 * W_m Motor Weight (see table)

Direct Drive RPM : 4-1150 RPM . 5-950 RPM

Motor kW	Fan RPM		Static Pressure in Inches wg									
			0	0.125	0.25	0.5	0.75	1	1.25	1.5	2	
450												
0.55	800	CFM	2257	2115	1934	1457						
		BKW	0.16	0.17	0.18	0.19						
	828	CFM	2336	2200	2032	1579	615					
		BKW	0.18	0.19	0.20	0.21	0.16					
	886	CFM	2500	2376	2228	1823	1237					
		BKW	0.22	0.23	0.24	0.25	0.24					
	944	CFM	2664	2550	2411	2059	1602	114				
		BKW	0.27	0.28	0.29	0.31	0.30	0.15				
	950	CFM	2681	2568	2430	2083	1638	237				
		BKW	0.27	0.28	0.29	0.31	0.31	0.17				
	1077	CFM	3039	2946	2824	2545	2199	1772	929			
		BKW	0.40	0.41	0.42	0.44	0.46	0.45	0.37			
0.75	1150	CFM	3245	3162	3048	2800	2497	2142	1647			
		BKW	0.48	0.49	0.50	0.53	0.56	0.55	0.53			
	1195	CFM	3372	3295	3185	2956	2670	2335	1926	1268		
		BKW	0.54	0.55	0.56	0.59	0.62	0.62	0.61	0.54		
1.10	1300	CFM	3668	3603	3502	3299	3049	2770	2456	2055		
		BKW	0.70	0.71	0.72	0.75	0.78	0.80	0.80	0.78		
	1357	CFM	3829	3769	3672	3479	3250	2999	2699	2397	1086	
		BKW	0.79	0.80	0.82	0.85	0.88	0.92	0.91	0.91	0.72	
1.50	1431	CFM	4038	3985	3893	3710	3508	3269	3006	2721	1892	
		BKW	0.93	0.94	0.95	0.99	1.02	1.06	1.07	1.07	0.99	
	1450	CFM	4092	4040	3950	3769	3573	3338	3083	2802	2045	
		BKW	0.97	0.97	0.99	1.03	1.06	1.10	1.12	1.11	1.05	
	1500	CFM	4233	4186	4098	3923	3744	3517	3285	3013	2366	
		BKW	1.07	1.08	1.10	1.13	1.17	1.20	1.24	1.23	1.20	

Performance certified by AMCA Accredited Laboratory for installation Type A : free inlet, free outlet per AMCA Standard 210. Performance rating includes the effects of a bird screen and wind band , However the product is not bearing AMCA Certified Seal .

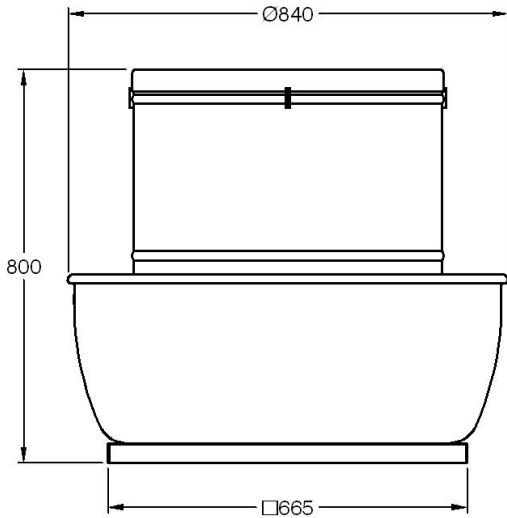

Damper Size = 438x438
 Roof Opening = 550x550
 *Approximate Unit Weight (kg) = 60 +W_m
 (All dimensions in millimeters)
 * W_m Motor Weight (see table)

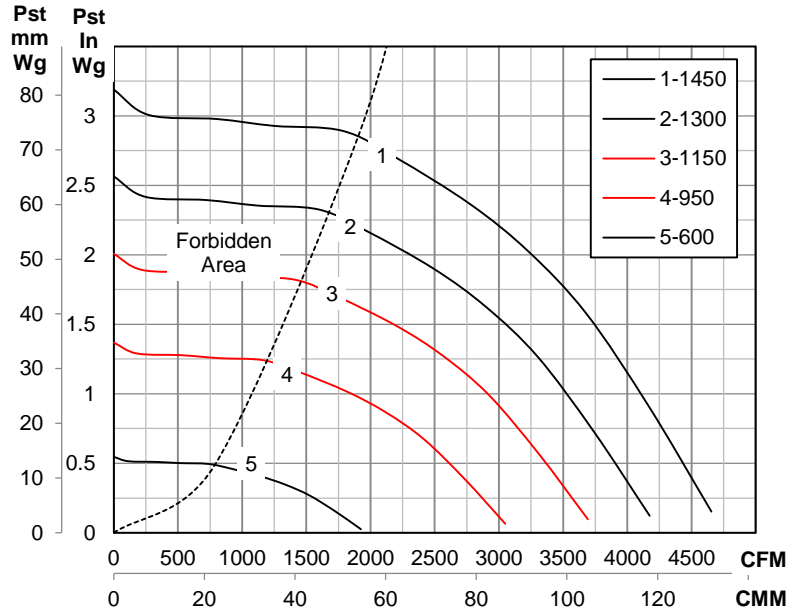

Direct Drive RPM : 3-1150 RPM . 4-950 RPM

Motor kW	Fan RPM		Static Pressure in Inches wg								
			0	0.25	0.5	0.75	1	1.25	1.5	2	
500											
0.75	600	CFM	1926	1559	568						
		BKW	0.10	0.11	0.09						
	730	CFM	2344	2070	1653	490					
		BKW	0.18	0.20	0.21	0.14					
	832	CFM	2671	2447	2137	1660					
		BKW	0.27	0.29	0.30	0.30					
	950	CFM	3050	2869	2609	2300	1850				
		BKW	0.41	0.42	0.44	0.46	0.45				
	1000	CFM	3211	3045	2803	2539	2156	1602			
		BKW	0.47	0.49	0.51	0.53	0.53	0.50			
	1053	CFM	3381	3231	3006	2756	2440	2010	1370		
		BKW	0.55	0.57	0.59	0.61	0.62	0.61	0.54		
1.10	1150	CFM	3692	3567	3364	3142	2910	2592	2175		
		BKW	0.72	0.73	0.76	0.78	0.81	0.81	0.79		
	1197	CFM	3843	3729	3534	3326	3105	2825	2472		
		BKW	0.81	0.83	0.85	0.88	0.90	0.91	0.90		
1.50	1262	CFM	4052	3953	3768	3576	3367	3140	2850	2003	
		BKW	0.95	0.97	0.99	1.02	1.05	1.07	1.07	1.00	
	1300	CFM	4174	4083	3903	3721	3518	3315	3039	2299	
		BKW	1.04	1.05	1.08	1.11	1.14	1.16	1.17	1.12	
	1327	CFM	4261	4175	3999	3823	3625	3426	3172	2505	
		BKW	1.11	1.12	1.15	1.17	1.20	1.23	1.24	1.21	
2.20	1417	CFM	4550	4481	4316	4151	3975	3789	3602	3066	
		BKW	1.35	1.36	1.39	1.42	1.45	1.48	1.51	1.51	
	1450	CFM	4842	4789	4634	4480	4323	4148	3973	3543	
		BKW	1.62	1.64	1.67	1.70	1.73	1.76	1.79	1.83	

Performance certified by AMCA Accredited Laboratory for installation Type A : free inlet, free outlet per AMCA Standard 210. Performance rating includes the effects of a bird screen and wind band , However the product is not bearing AMCA Certified Seal .

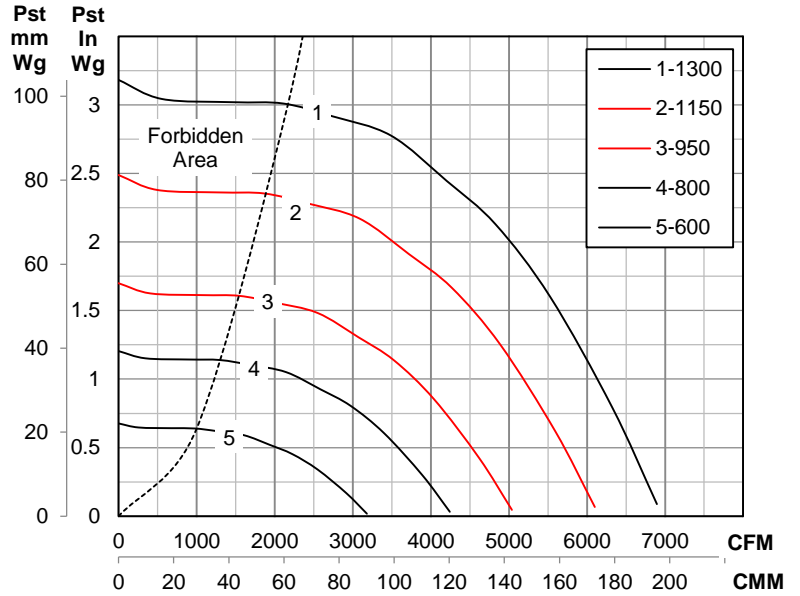
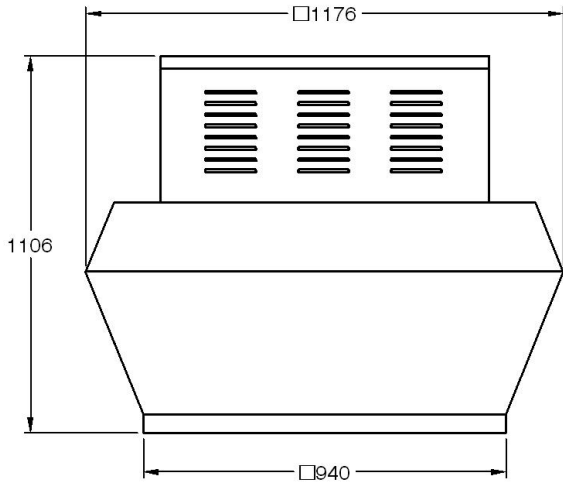

Damper Size = 605x605
 Roof Opening = 715x715
 *Approximate Unit Weight (kg) = 118 +W_m
 (All dimensions in millimeters)
 *W_m Motor Weight (see table)

Direct Drive RPM: 2-1150 RPM . 3-950 RPM

Motor kW	Fan RPM		Static Pressure in Inches wg								
			0	0.25	0.5	0.75	1	1.25	1.5	2	
560											
1.10	600	CFM	3182	2745	2028						
		BKW	0.16	0.19	0.20						
	687	CFM	3644	3288	2787	1945					
		BKW	0.24	0.28	0.30	0.30					
	735	CFM	3898	3579	3145	2486					
		BKW	0.29	0.33	0.37	0.38					
	784	CFM	4158	3864	3467	2964	2137				
		BKW	0.36	0.40	0.43	0.46	0.44				
	800	CFM	4243	3957	3571	3091	2325				
		BKW	0.38	0.42	0.46	0.48	0.47				
	869	CFM	4609	4353	4011	3625	3082	2251			
		BKW	0.48	0.53	0.57	0.61	0.62	0.58			
	950	CFM	5039	4813	4517	4180	3775	3221	2416		
		BKW	0.63	0.68	0.73	0.78	0.80	0.81	0.76		
	988	CFM	5240	5027	4750	4426	4068	3615	2943		
		BKW	0.71	0.76	0.82	0.86	0.90	0.92	0.89		
1.50	1042	CFM	5527	5330	5077	4772	4464	4063	3542		
		BKW	0.83	0.88	0.95	0.99	1.04	1.07	1.07		
	1095	CFM	5808	5626	5386	5106	4813	4475	4082	2740	
		BKW	0.97	1.02	1.08	1.14	1.19	1.22	1.25	1.15	
2.20	1150	CFM	6100	5933	5703	5448	5170	4892	4518	3504	
		BKW	1.12	1.17	1.24	1.30	1.35	1.41	1.43	1.42	
	1245	CFM	6603	6459	6247	6031	5774	5517	5248	4524	
		BKW	1.42	1.47	1.55	1.62	1.68	1.74	1.79	1.83	
3.00	1300	CFM	6895	6763	6560	6357	6118	5872	5625	4997	
		BKW	1.62	1.67	1.75	1.83	1.89	1.95	2.01	2.08	

Performance certified by AMCA Accredited Laboratory for installation Type A : free inlet, free outlet per AMCA Standard 210. Performance rating includes the effects of a bird screen and wind band , However the product is not bearing AMCA Certified Seal .

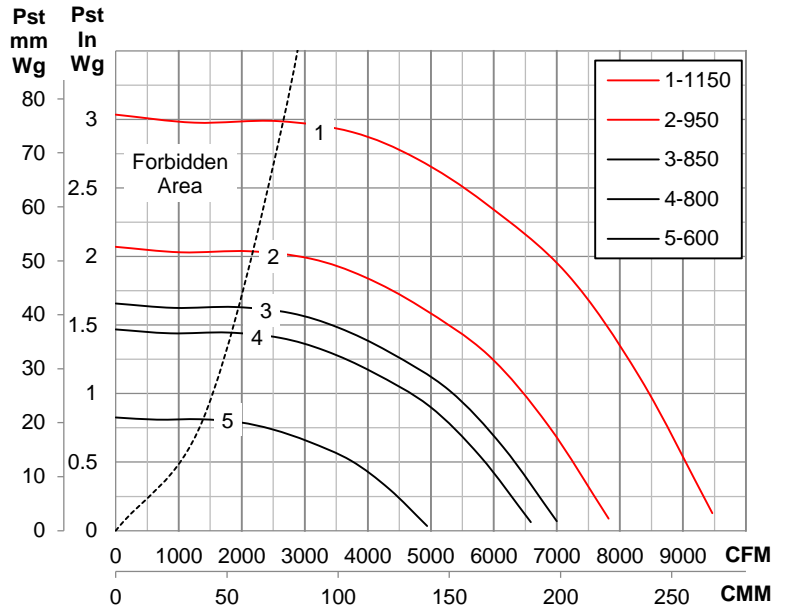
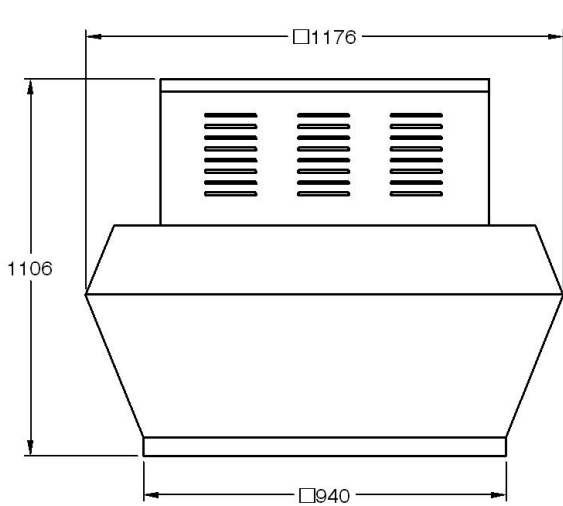

Damper Size =605X605
 Roof Opening =715x715
 *Approximate Unit Weight (kg) = 119 +W_m
 (All dimensions in millimeters)
 * W_m Motor Weight (see table)

Direct Drive RPM: 1-1150 RPM . 2-950 RPM

Motor kW	Fan RPM		Static Pressure in Inches wg								
			0	0.25	0.5	0.75	1	1.25	1.5	2	
630											
1.10	600	CFM	4941	4461	3766	2377					
		BKW	0.27	0.31	0.34	0.31					
	659	CFM	5426	5004	4412	3513					
		BKW	0.36	0.40	0.44	0.45					
	695	CFM	5723	5332	4795	4056	2808				
		BKW	0.42	0.46	0.51	0.53	0.49				
	731	CFM	6019	5657	5171	4570	3544				
		BKW	0.49	0.54	0.59	0.62	0.60				
	781	CFM	6431	6104	5676	5121	4361	3251			
		BKW	0.60	0.64	0.70	0.74	0.75	0.70			
	800	CFM	6587	6273	5855	5327	4646	3627			
		BKW	0.65	0.69	0.75	0.79	0.81	0.77			
	831	CFM	6843	6548	6146	5659	5101	4224	2845		
		BKW	0.72	0.77	0.83	0.88	0.92	0.90	0.79		
1.50	850	CFM	6999	6716	6323	5860	5343	4523	3404		
		BKW	0.78	0.82	0.88	0.93	0.98	0.97	0.89		
	876	CFM	7213	6945	6563	6133	5631	4918	3966		
		BKW	0.85	0.89	0.96	1.01	1.06	1.06	1.01		
	921	CFM	7584	7340	6977	6599	6121	5586	4799		
		BKW	0.99	1.03	1.10	1.16	1.21	1.25	1.23		
2.20	950	CFM	7823	7594	7242	6890	6432	5970	5242	2810	
		BKW	1.08	1.13	1.20	1.27	1.32	1.37	1.35	1.10	
	1047	CFM	8621	8438	8118	7799	7450	7030	6610	5264	
		BKW	1.45	1.49	1.57	1.64	1.71	1.77	1.82	1.79	
3.00	1150	CFM	9469	9328	9037	8746	8455	8116	7734	6845	
		BKW	1.92	1.96	2.04	2.13	2.21	2.28	2.34	2.42	

Performance certified by AMCA Accredited Laboratory for installation Type A : free inlet, free outlet per AMCA Standard 210. Performance rating includes the effects of a bird screen and wind band , However the product is not bearing AMCA Certified Seal .

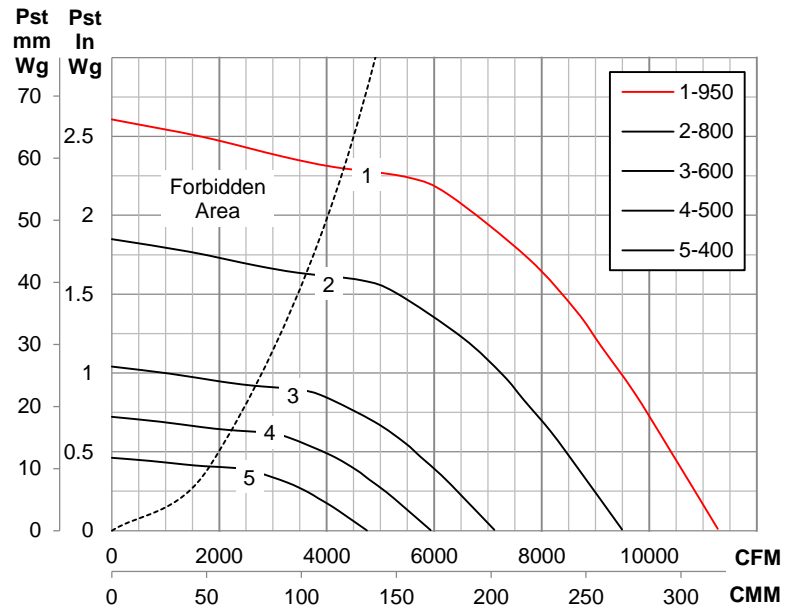
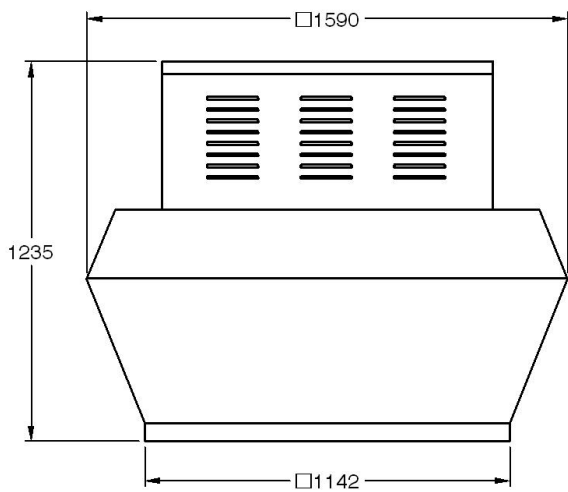

Damper Size = 875X875
 Roof Opening = 930x930
 *Approximate Unit Weight (kg) = 252 +W_m
 (All dimensions in millimeters)
 * W_m Motor Weight (see table)

Direct Drive RPM : 1-950 RPM

Motor kW	Fan RPM		Static Pressure in Inches wg										
			0	0.25	0.5	0.75	1	1.25	1.5	2			
800													
1.5	400	CFM	4746	3576									
		BKW	0.27	0.28									
	475	CFM	5636	4700	3359								
		BKW	0.45	0.47	0.45								
	500	CFM	5933	5086	3925								
		BKW	0.50	0.53	0.52								
	527	CFM	6253	5445	4413	1184							
		BKW	0.62	0.64	0.64	0.35							
	554	CFM	6504	5825	4863	3132							
		BKW	0.70	0.73	0.73	0.64							
600	CFM	7119	6425	5639	4536								
	BKW	0.87	0.91	0.92	0.90								
609	CFM	7150	6549	5749	4756	1319							
	BKW	0.93	0.96	0.98	0.95	0.52							
664	CFM	7796	7260	6603	5712	4590							
	BKW	1.21	1.23	1.26	1.26	1.20							
2.2	737	CFM	8634	8206	7618	6910	6129	5028					
		BKW	1.63	1.66	1.70	1.72	1.70	1.62					
	754	CFM	8833	8418	7857	7168	6417	5551	2328				
		BKW	1.74	1.78	1.82	1.84	1.82	1.77	1.13				
3	800	CFM	9493	8981	8446	7863	7236	6412	5321				
		BKW	2.06	2.11	2.16	2.18	2.19	2.16	2.06				
	811	CFM	9501	9127	8647	8017	7361	6630	5631				
		BKW	2.17	2.21	2.25	2.28	2.29	2.26	2.17				
	836	CFM	9794	9436	8990	8383	7750	7056	6278				
		BKW	2.37	2.41	2.46	2.50	2.50	2.48	2.43				
4	900	CFM	10679	10228	9757	9276	8733	8185	7478	5295			
		BKW	2.93	2.99	3.05	3.09	3.11	3.12	3.09	2.82			
	921	CFM	10928	10488	10029	9559	9039	8502	7848	6081			
		BKW	3.14	3.20	3.27	3.31	3.33	3.35	3.32	3.14			
5.5	950	CFM	11272	10847	10402	9948	9458	8935	8352	6742			
		BKW	3.44	3.51	3.58	3.62	3.65	3.67	3.66	3.51			

Performance certified by AMCA Accredited Laboratory for installation Type A : free inlet, free outlet per AMCA Standard 210. Performance rating includes the effects of a bird screen and wind band , However the product is not bearing AMCA Certified Seal .

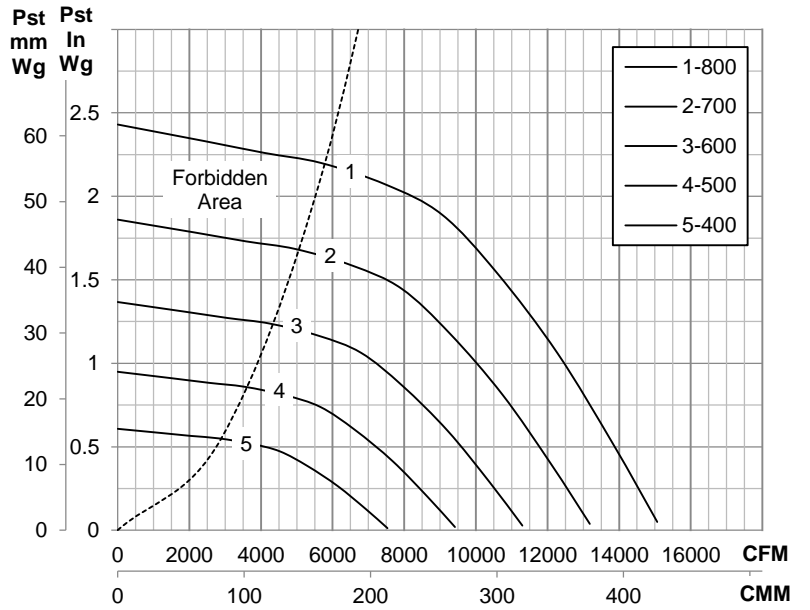
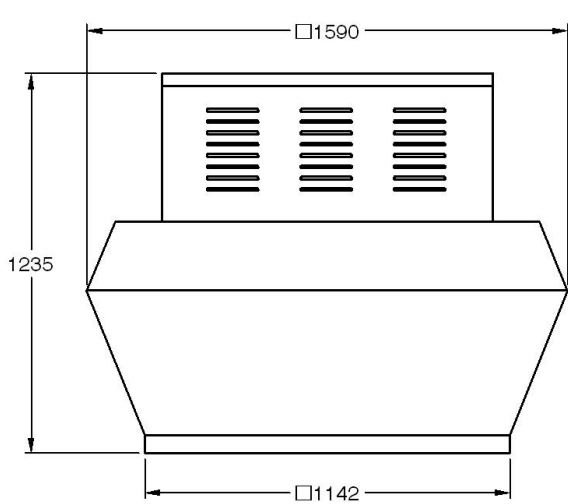

Damper Size = 875X875

Roof Opening = 930x930

*Approximate Unit Weight (kg) = 258 + W_m

(All dimensions in millimeters)

* W_m Motor Weight (see table)

Motor kW	Fan RPM		Static Pressure in Inches wg								
			0	0.25	0.5	0.75	1	1.25	1.5	2	
900											
1.5	363	CFM	6917	5276							
		BKW	0.47	0.49							
	403	CFM	7464	6215	3844						
		BKW	0.63	0.66	0.60						
	439	CFM	8131	7082	5445						
		BKW	0.82	0.85	0.84						
	458	CFM	8483	7530	5949	1159					
		BKW	0.93	0.96	0.96	0.50					
	483	CFM	9176	8035	6766	4318					
		BKW	1.05	1.10	1.10	0.99					
	507	CFM	9632	8545	7389	5628					
		BKW	1.22	1.26	1.28	1.23					
2.2	531	CFM	10088	9050	7955	6573	1914				
		BKW	1.40	1.45	1.47	1.45	0.86				
576	CFM	10943	9986	8991	7856	6040					
	BKW	1.79	1.84	1.87	1.87	2					
3	585	CFM	11017	10203	9171	8073	6555	1823			
		BKW	1.86	1.90	1.94	1.94	1.88	1.04			
	639	CFM	12034	11302	10418	9401	8270	6612	1863		
		BKW	2.43	2.47	2.51	2.53	2.50	2.39	1.32		
4	643	CFM	12109	11383	10509	9496	8386	6804	2155		
		BKW	2.47	2.52	2.56	2.58	2.55	2.45	1.43		
	704	CFM	13258	12609	11872	10939	10040	8939	7435		
		BKW	3.25	3.29	3.35	3.38	3.38	3.34	3.22		
5.5	782	CFM	14726	14180	13502	12772	12042	11152	10228	7005	
		BKW	4.39	4.44	4.50	4.54	4.57	4.57	4.55	4.13	
	800	CFM	15065	14537	13877	13166	12452	11614	10735	8099	
		BKW	4.70	4.75	4.81	4.85	4.89	4.89	4.88	4.63	

Performance certified by AMCA Accredited Laboratory for installation Type A : free inlet, free outlet per AMCA Standard 210. Performance rating includes the effects of a bird screen and wind band , However the product is not bearing AMCA Certified Seal .

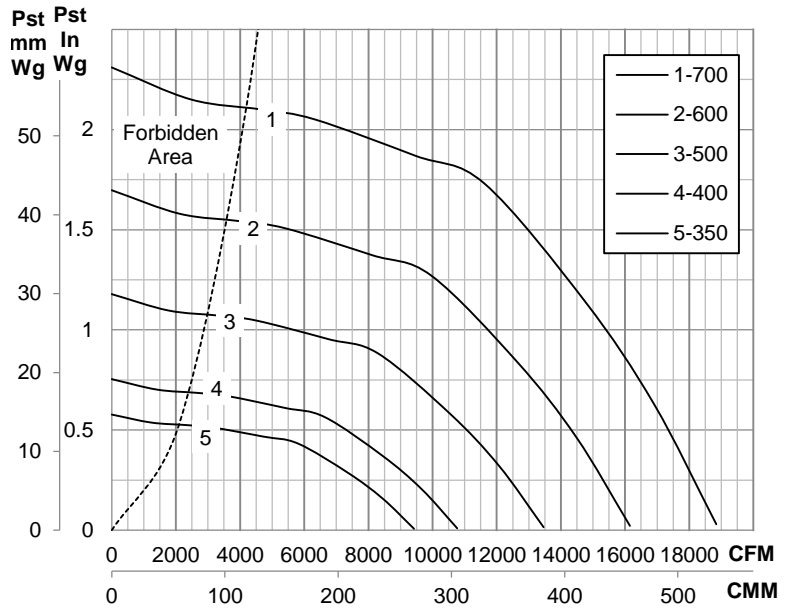
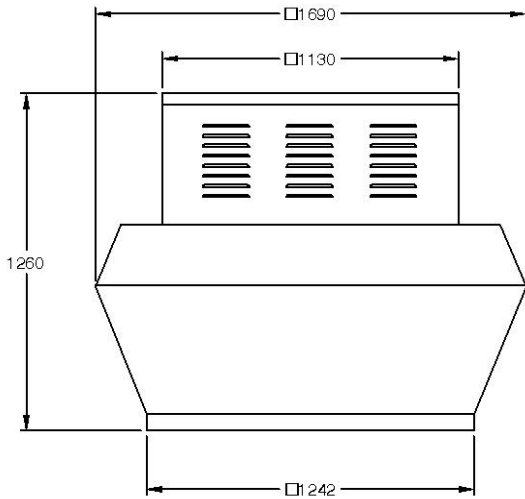

Damper Size = 900x900
 Roof Opening = 1030x1030
 *Approximate Unit Weight (kg) = 305 +W_m
 (All dimensions in millimeters)
 * W_m Motor Weight (see table)

Motor kW	Fan RPM		Static Pressure in Inches wg								
			0	0.25	0.5	0.75	1	1.25	1.5	2	
1000											
2.2	350	CFM	9422	7674							
		BKW	0.71	0.73							
	377	CFM	10085	8313							
		BKW	0.91	0.94							
	400	CFM	10768	9333	7245						
		BKW	1.06	1.09	1.07						
	418	CFM	11259	9929	8060						
		BKW	1.22	1.26	1.25						
	456	CFM	12283	11069	9470	6947					
		BKW	1.58	1.62	1.63	1.52					
	475	CFM	12795	11632	10140	8151					
		BKW	1.79	1.83	1.84	1.79					
3.0	502	CFM	13522	12427	11074	9416	5952				
		BKW	2.11	2.16	2.17	2.15	1.82				
	527	CFM	14196	13156	11923	10465	8054				
		BKW	2.45	2.49	2.51	2.51	2.35				
4.0	552	CFM	14830	13845	12712	11373	9675				
		BKW	2.80	2.85	2.89	2.90	2.83				
	580	CFM	15582	14656	13604	12347	10879	8194			
		BKW	3.25	3.29	3.35	3.36	3.32	2.98			
5.5	607	CFM	16437	15414	14351	13157	11883	10322			
		BKW	3.70	3.76	3.81	3.82	3.79	3.70			
	645	CFM	17466	16503	15540	14416	13291	11998	9717		
		BKW	4.43	4.50	4.57	4.58	4.58	4.52	4.27		
7.5	668	CFM	17983	17227	16379	15354	14254	12905	11510		
		BKW	4.93	4.99	5.06	5.08	5.10	5.03	4.95		
	700	CFM	18844	18132	17322	16398	15349	14176	12845	7206	
		BKW	5.68	5.74	5.81	5.85	5.86	5.83	5.74	4.53	

Performance certified by AMCA Accredited Laboratory for installation Type A : free inlet, free outlet per AMCA Standard 210. Performance rating includes the effects of a bird screen and wind band , However the product is not bearing AMCA Certified Seal .

Options & Accessories

Roof Curbs

Pre-fabricated roof curbs are made of galvanized steel sheet. All roof curbs are insulated with fiber glass / rock wool.

A wide variety of roof curbs are available, including flange and sound absorbing wool.

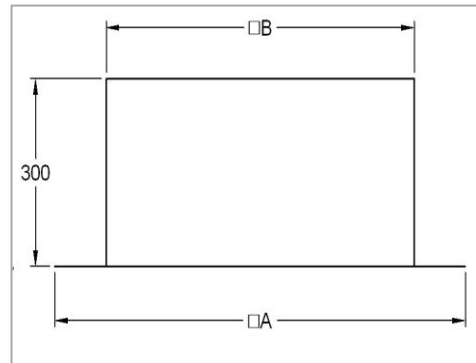
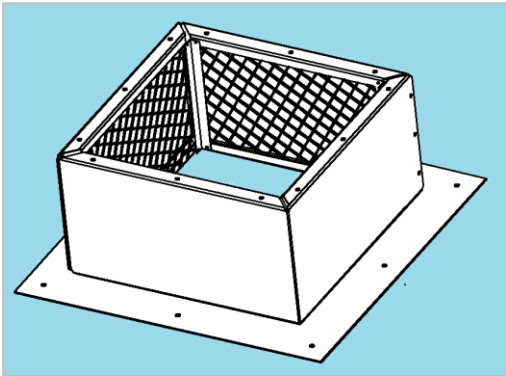

Size	B	A
DV 310	598	800
DV 355		
DV 400		
DV/W 450	663	865
DVW 500		
DVW 560	938	1180
DVW 630		
DVW 800	1137	1740
DVW 900		
DVW 1000	1237	1840

Dampers :

Dampers are designed to prevent outside air from entering back into the building when fan is off,

Damper sizes are shown on each performance data page.



Disconnecting Switches

A wide range selection of NEMA rated Switches are available for positive electrical shutoff and safety, including dust tight, rainproof, corrosion resistant.

Switches may be internally or externally mounted.



Options & Accessories

Speed Controllers :

VFD : Variable frequency Drive is a type of motor controller that drives an electric motor by varying the frequency and voltage supplied to the electric motor.



Motor Starters:

The function of a motor Starter is to protect the motor from damage that can occur from overheating and high starting current .



Grease Trap (Kitchen Fan):

Steel trap designed to collect grease residues to avoid drainage onto roof surfaces

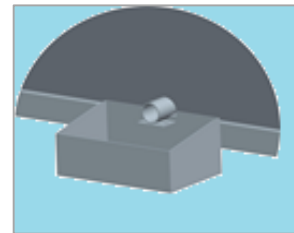

Cooling Tube (Kitchen Fan):

Cooling fins located on top of fan wheel draw outside air through a large breather tube directly into the motor compartment. Positive motor cooling with fresh air results in maximum motor life.

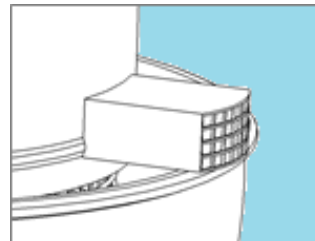

Vented Curb (Kitchen Fan):

Mounts between roof and roof mounted fan , Provided vents on side walls

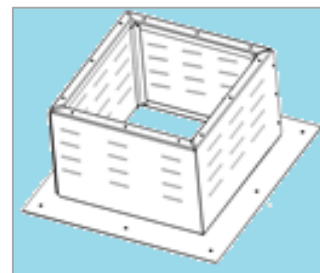

Centrifugal Roof Exhaust Fans

Motor Weight :

The following Table Showing Weight for Standard 4 pole Motors.

Motor (KW)	0.18	0.25	0.37	0.55	0.75	1.1	1.5	2.2	3	4	5.5	7.5
Weight (Kg)	4.6	5	6.9	9.6	10.9	13.8	16.7	23	34	46	55	64

Typical Installation by Application

General Clean Air

All exhaust fans are designed for clean air applications. A typical installation is shown in fig.

- For recommended Damper size and roof opening dimensions, refer to the performance data pages.
- Installation must include a means for inspecting, cleaning and servicing the exhaust fan.

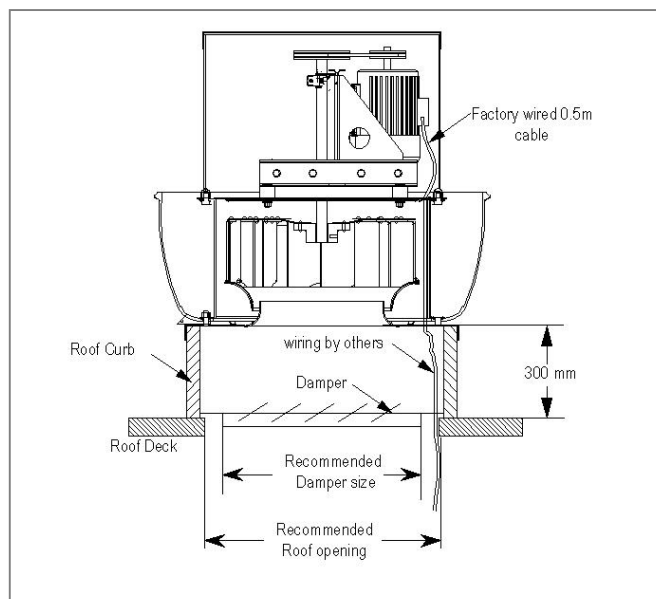

Commercial Kitchen (Grease)

All models are designed to meet restaurant and food service application with additional grease collector and cooling tube ,

- Exhaust fans used in kitchen ventilation applications must have external wiring.(Wiring must not be installed in the airstream).
- No dampers are to be installed in the system.

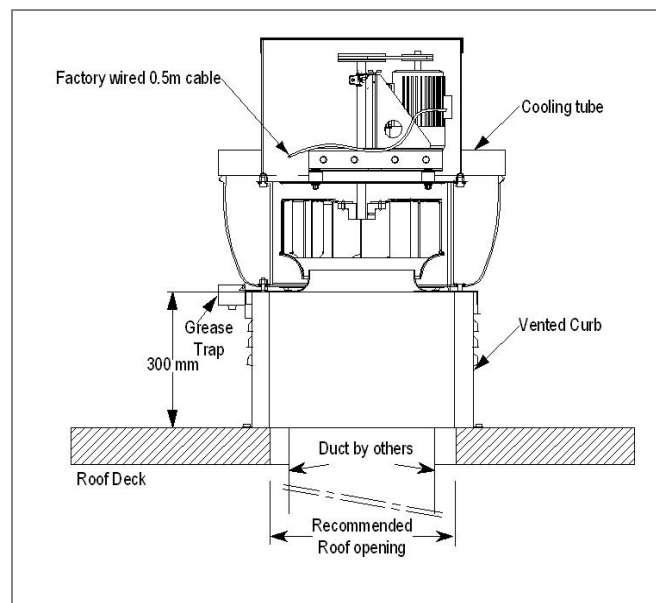

Fan - Pre Start Check list

Fan Type: _____

(Refer to fan name plate)

After the fan installation, all the items below should be checked by the maintenance personnel before start running the fan.

Check the items if Yes / No or Not Applicable (N/A) .Check the appropriate box.

1. Ensure the fan and ductwork are clean and no tools and other object left.

Yes No

2. Inspect the tightness of fasteners ,bolts and screws ,such as motor mounting bolts, bushing screws, bearing bolts, fan shaft screws ,impeller fasten bolts, installation bolts, vibration insulators,... etc. .(fan should not damage during shipment).

Yes No

3. Impeller must rotate freely and not rub on the inlet venturi .

Yes No

4. Proper pulley alignment (pulley might be misaligned during fan shipment) .

Yes No N/A

5. Proper belt tension.

Yes No N/A

6. The fan and motor should be electricity grounding.

Yes No

7. Ensure the power supply, wiring and Amperage are in accordance with the motor name plate. Actual

Testing ampere : _____ Rated ampere (motor name plate) : _____

Yes No

8. Wiring connection should confirm the correct impeller rotation.

Clock-Wise (CW) Counter Clock-Wise

9. The power supply should have motor overload protector .Ensure that thermal protection of the motor should be connected.

Yes No

10. Ensure the motor insulation is accordance with the electrifying requirements.

Yes No

Checked By: _____

Date: _____

Name & Signature

Note:

- The fan can be start up and run if all the above items are checked.
- This check list should be submitted to the manufacturer together with the customer complaint, warranty/maintenance claim (if any) .

Warranty

Saudi Fan Industries warrants this equipment to be free from defects in material and workmanship for a period of One year from the Delivery date.

Limitation & Exclusions:

- This warranty will cover for defective parts only excluding labor.
- The warranty does not cover the following
 - a. Defects or malfunction resulting from mishandling , improper operation
 - b. Damage caused by abuse, accident, fire, flood.....etc. :and
 - c. Defects due to absence of magnetic starters sized to correct overload rating
- Any units or parts, which proved defective during the warranty period will be replaced at our option when returned to our factory.

Saudi Fan Industries

For contacts & inquiry

Refrigeration House Group
P. O. Box 1823 - Al-Khobar 31952
SAUDI ARABIA

■ **Head Office** (Sales & Marketing)
Tel. : (03) 882 1713 - 882 3515 Fax : (03) 882 3066
E-mail : sales@refhouse.com / rhadmin@refhouse.com

■ **Manufacturing Divisions**
Dammam 2nd Industrial City
National Factory Tel. : (03) 812 1282 Fax : (03) 812 1280
Saudi Fan Industries Tel. : (03) 812 1866 Fax : (03) 812 1894

■ **Contracting Divisions**
Klimatechnik Tel. : (03) 882 3534 Fax : (03) 882 2807
Riyadh Tel. : (01) 465 6198 Fax : (01) 462 8347

■ **Trading Divisions**
Refrigeration House
Al-Khobar Tel. : (03) 869 1043 Fax : (03) 898 4161
Riyadh Tel. : (01) 476 9720 Fax : (01) 477 5430
Jeddah Tel. : (02) 665 2276 Fax : (02) 661 2265

www.refhouse.com

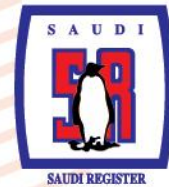

Klimatechnik





Centrifugal Roof Fan
Direct Drive DH / DV

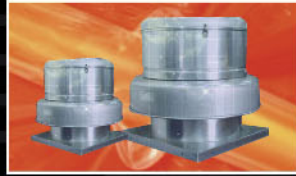

Centrifugal Roof Fan
Belt & Direct Driven/RTC



Centrifugal Radial Fan
Direct Drive ERAE-ERAD / DRAE-DRAD



Centrifugal Radial Fan
Belt Driven HRE-TRE / HRZ-TRZ



Square Inline Fans
Belt & Direct Driven / ISG



Fresh Air Musfan
Belt & Direct Driven MU



Air Box Fresh Air Fan
Belt & Direct Driven AirBox



Centrifugal Twin Fan
Belt & Direct Driven TW



Axial Low Pressure Fan
Direct Drive EQ / DQ



Axial High Pressure Fan
Direct Drive AND



Inline Centrifugal Duct Fan
Direct Drive EKAE / EKAD



Inline Centrifugal Tube Fan
Direct Drive R / RS



Centrifugal Silent Fan
Direct Drive SSF



Axial Circulation Fan
Direct Drive SACF 30" - 36"



Axial Agricultural Fan
Direct Drive SAAF 125"



Axial Portable Tunnel Fan
Direct Drive SPTF 8" - 12"